

Dual Operator Workstation Continuous Monitor Operation, Installation and Maintenance



Made in America

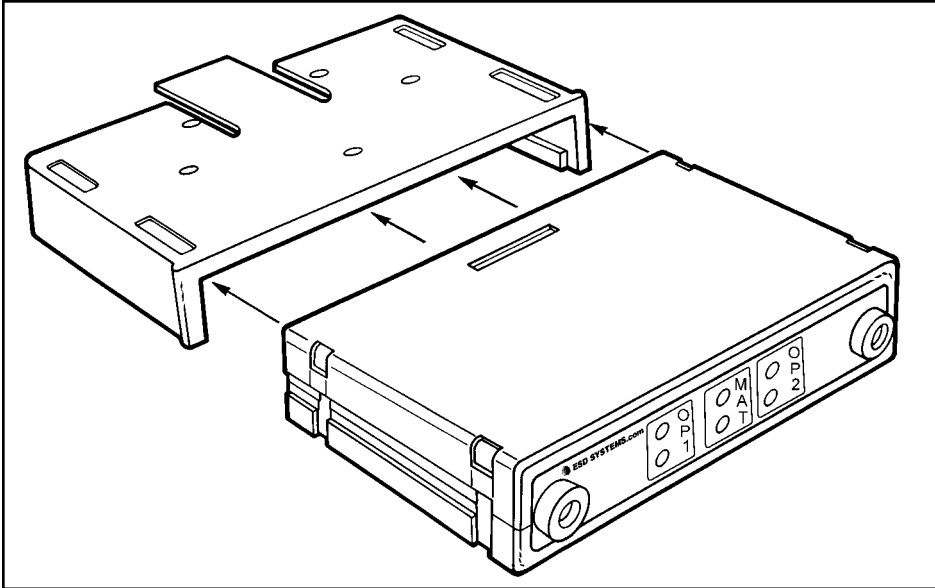

Figure 1. ESD Systems.com 41137 Dual Operator Workstation Continuous Monitor.

Description

Leading companies use continuous monitors as a cost effective component in satisfying the paragraph 6.1.3 Compliance Verification Plan requirements of ANSI/ESD S20.20. The ESD Systems.com 41137 Dual Operator Workstation Continuous Monitor continuously monitors the grounding integrity of two operators, and an ESD protective work surface's discharge path to ground. The monitor will provide virtually instantaneous notification of static control equipment failures, eliminating the need of costly record keeping. The 41137 is highly cost effective as it is designed to monitor any conventional single conductor wrist strap and ground cord system.

The Dual Operator Workstation Continuous Monitor is an impedance sensing device designed to monitor body types from a 5th percentile female to a 95th percentile male. This range covers a 5 foot tall 90 pound person to a 6 foot 5 inch 250 pound

person in any production environment.* The 41137 is powered by a 120 VAC, 60/50 Hz, plug-in transformer.

No user adjustment required: The Continuous Monitor is drift-free and designed to be insensitive to the effects of squeezing or stretching the coil cord. It requires no user adjustment or calibration.

The Dual Operator Workstation Continuous Monitor is a Real Time instrument that ensures that critical ESD generators in a sensitive area are effectively grounded. It independently monitors the operator and the work surface. The instant an operator's wrist strap or cord fails, the monitor will issue audible and visual alarms alerting the user of the problem. In the same manner, the unit also confirms that an electrical discharge path to ground of less than 500 megohms exists from the ESD protective work surface. No user adjustment or calibration required.

ADVANTAGES OF CONTINUOUS MONITORING OVER PERIODIC TESTING

Many customers are eliminating periodic testing and are utilizing continuous monitoring to better ensure that their products were manufactured in an ESD protected environment. Full time continuous monitoring is superior to periodic or pulsed testing, and can save a significant amount of money in testing costs and rejected product. Periodic testing detects failures after ESD susceptible products have been manufactured. The costs of dealing with the resulting catastrophic or latent defects can be considerable. Dual Operator Workstation Continuous Monitors eliminate the need for users to test wrist straps and log the results; by their function, these monitors satisfy the ISO 9000 and ANSI/ESD S20.20 test logging. ANSI/ESD S20.20 Paragraph 6.2.2.2 Personnel Grounding Guidance states "A log should be maintained which verifies that personnel have tested their personal grounding devices." Per ESD-S1.1 Paragraph 6.1.3 "Daily (wrist strap system) testing may be omitted if constant monitoring is used."

WAVE DISTORTION DETECTION TECHNOLOGY PROVIDES TRUE 100% CONTINUOUS MONITORING

From all the technical alternatives available, ESD Systems.com has chosen wave distortion technology for all its Continuous Monitor product offerings. Wave distortion circuitry monitors current/voltage phase shifts and provides true 100% continuous monitoring. Electrical current will lead voltage at various points due to

*NASA Publication 1024-Anthropomorphic Source Book Volume 1: "Anthropometry for Designers"

the combinations of resistance and capacitive reactance. By monitoring these “distortions” or phase shifts, the wave distortion Workstation Continuous Monitor will reliably determine if the circuit is complete. Wave distortion technology can be referred to as “vector impedance monitoring”. This description is valid as the wave distortion technology measures the impedance at the monitored banana jack and looks for changes in either the capacitance or resistance of the circuit which includes the wrist strap and its wearer. It uses filtering and time domain sampling to filter out false signals caused by voltage offsets, 60 Hz fields and other electro-magnetic and electrostatic interference.

In normal factory environments, and with persons whose capacitance with respect to ground is within design limits (5 feet tall 90 pound person to 6 foot 5 inch 250 pound person), the Dual Operator Workstation Continuous Monitor cannot be “fooled”. It will provide a reliable alarm only when the wrist strap or work surface becomes dysfunctional or unsafe according to accepted industry standards. The Dual Operator Workstation Continuous Monitor is drift-free and designed to be insensitive to the effects of squeezing or stretching the coil cord.

ADVANTAGES OF WAVE DISTORTION AND SINGLE-WIRE TECHNOLOGY

The ESD Systems.com Dual Operator Workstation Continuous Monitor allows the use of any standard, single-wire wrist strap and coil cord. The monitor/wrist strap/cord system life-cycle costs are by far lower than alternative systems which require expensive & fragile dual-wire cords and special wrist straps. Dual-wire cords are expensive and are the weak

link of the system, the most likely component to need replacement. Over a five year period, this can make the dual-wire system three to five times as expensive as a system utilizing single-wire wrist straps and cords.

The dictionary defines constant as uniform and unchanging, and continuous as uninterrupted. Nonetheless, some dual-wire resistance monitors utilize a pulsed test current and do not really provide continuous monitoring. For example, during each 2.2 second pulse cycle of a leading “constant” resistive monitor, electrical current is pulsed for only 0.2 seconds followed by an unmonitored interval of 2 seconds. This leaves the user/wrist strap unmonitored for over 90% of each cycle. Damaging static charges can easily occur in the portion of the time in between the pulses. The off period of 2 seconds equals 2 billion nanoseconds, and “it takes only about 25 volts applied for 100 nanoseconds to blow most memories or microprocessors”.* The dual-wire system does not reliably meet all industry specifications, as the cords do not meet the EOS/ESD Association guidelines for the 1 to 5 pound “breakaway force” requirement for operator safety.

By using the reliable wave distortion technology to determine if the circuit is complete, there are no false alarms. There is no need to adjust or tune the monitor to a specific user or installation. The miniscule amount of electrical current (less than 1 volt coil cord signal) required to generate the waveform has never caused reported skin irritation and is extremely safe for use in voltage sensitive applications such as disk drive manufacturing.

Installation

Confirm that worksurface is 5×10^8 ohms or less. Remove the monitor from its packaging and inspect for any shipping damage. Included with each Dual Operator Workstation Continuous Monitor should be:

- 1 120 VAC transformer
- 1 Work surface ground cord
- 1 Push and clinch snap (12100)
- 2 Remote Jacks (41103)
- 2 Mounting screws

Model 41137 is normally installed under the bench top toward the front edge of a workstation where the LEDs are easily visible. The unit is designed to be mounted using the mounting bracket provided. See figure 2. To release monitor, push up on the monitor release tab.

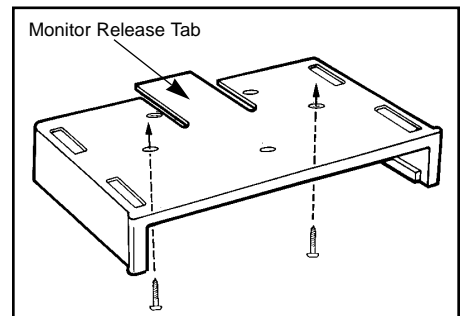

Figure 2. Installation of mounting bracket.

Figure 3 shows the monitor as it is viewed from the front.

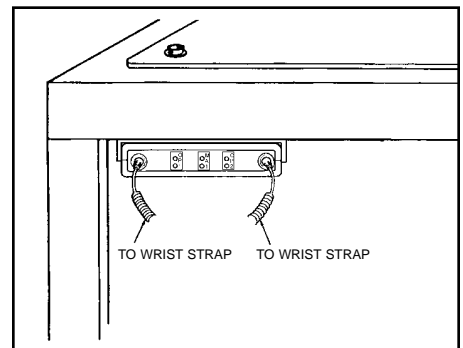
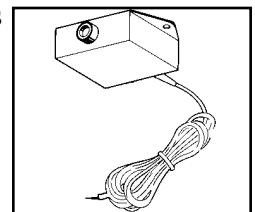

Figure 3. Operating the 41137 monitor.

REMOTE JACKS

The remote jacks allow you to install the continuous monitor up to 6 feet away from the base unit.



Two persons can be monitored at separate adjacent workstations.

*1981 article by Donald E. Frank - Electrical Overstress Electronic Discharge Symposium Proceedings

Figure 4 shows the monitor as it is viewed from the rear, with the work surface wiring in place.

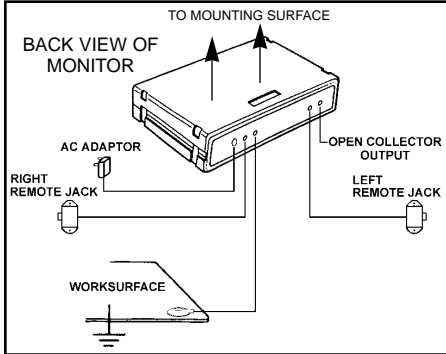

Figure 4. Wiring connection instructions for the 41137.

The following procedure will outline how to correctly wire the 41137 so as to properly monitor an ESD protected workstation.

1. Use rear access connections when using monitor with remote jacks. Access holes are provided on the bottom of the unit to loosen/tighten connections. See Figure 4 for wiring connection instructions. After remote jacks are mounted, route wires using a direct route; try to avoid running wires adjacent to metal, if possible.
2. Verify that a ground cord is properly connected to snap socket on one corner of the ESD work surface. The other end of the ground cord must be attached to a known good ground point.
3. **Confirm that worksurface surface resistance is 5×10^8 ohms or less.** Connect the stripped end of the work surface cord included with the unit to the terminal marked "Work Surface" on the back of the unit. Snap the other end to the worksurface as shown in figures 4 and 5.
4. A convenient 120 VAC outlet should be located and tested for proper wiring and grounding. We recommend ESD Systems.com Item 41110 AC Outlet Analyzer to verify integrity of building ground point.

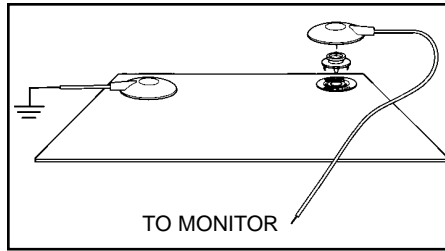

Figure 5. Installing cords on the worksurface.

5. Plug the transformer into the outlet and connect the mini plug into the back side of the monitor. The green Work Surface LED should be lit. The monitor is now ready for use. If the red Work Surface LED is flashing, check the snap fasteners and ground cords for proper connection.

Installation on Micastat® Laminate

Materials Needed:

- 2 14244 Flush Mount Ground Laminate Inserts
 - 1 14242 Installation Tool for Flush Mount Insert
1. Install the Flush Mount Inserts first. It is recommended to install one in the right back corner and the other in the left back corner of the Micastat® laminated bench top.
 2. Once both inserts are installed, cut the ground cord supplied with the monitor into two pieces; make sure that the tinned end is long enough to connect from the monitor to one of the flush mount terminals located under the bench.
 3. The remaining wire can then be used to connect the other flush mount terminal to ground using the supplied ring terminal. The shrouded molded end can then be cut off.

When complete, one flush mount terminal will connect the Micastat® laminate to ground, while the other will connect it to a monitor. The monitor then monitors the ground connection between the two inserts,

and since Micastat® is the only ESD laminate made with a physical uniform ground layer, it will monitor the entire Micastat® surface ground. The wires will stay under the bench, maximizing the usable space on the bench top.

Operation

When the 41137 monitor is installed and is connected to a grounded ESD protective work surface, the monitor's green Work Surface LED and its two red Operator LEDs should be on.

TO USE THE MONITOR:

1. Plug a wrist strap cord, not attached to the wristband, into either of the monitored jacks on the front of the unit. This automatically activates the selected operator channel. The red Operator LED should turn on and the audio alarm should beep.
2. Snap the cord to the wristband, and slip it on your wrist. (It should fit snugly.) This should silence the audio and cause the LEDs to switch from red to green. If this does not happen, check the coil cord for continuity or damage. Examine your wrist and ensure that it has a secure fit. If you have dry skin use antistatic hand lotion such as ESD Systems.com item 16009 Reztore™ ESD Hand Lotion. When leaving the area, a person can take the coil cord along or leave it attached to the monitor. In either case the audio alarm will only sound for about eight seconds.

Whenever the coil cord is accidentally withdrawn from the monitor, or if continuity from the user to the monitor is not maintained, the alarm sounds, the green Operator LED turns off and the red Operator LED turns on.

COMPUTER INTERFACE

The model 41137 monitor also incorporates logic output circuitry. The unit is designed with an open collector circuit that can be set up to activate remote sirens, alarms or

interface with a computer. The open collector circuit is accessible through the terminal screw on back of the monitor. See figure 4 for location.

WORK SURFACE CHANNEL

The 41137 Work Surface monitoring circuitry is sufficiently sensitive to detect extremely low current, **allowing it to be used with mats having a resistance of up to 5×10^8 ohms.**

When the monitor is connected to a static dissipative work surface, the amount of current that flows is a function of the total resistance between the monitor and through the work surface to ground. When the resistance of the work surface is below a present threshold, the monitor will indicate good. Conversely, if the resistance level is high when compared to the monitor's reference, the unit will alarm. This is an integrating resistance measuring circuit, therefore it is relatively insensitive to externally induced electromagnetic fields. The resistance threshold is factory set to 500 megohms. Custom worksurface range available upon request. Call for details.

Specifications

Work Surface Limit*
Set to 500 Megohms

Operating Voltage
120 VAC, 50-60 Hz

Response time to alarm
< 50 mS

Operating Temperature
0 - 40°C

Long Term Drift
<0.5% per Decade
(1st Decade is 1 hr)

Size (less bracket)
3.25 x 4.75 x 1.1

*Limits can be varied and set to 1 gigohm maximum.

OPEN COLLECTOR OUTPUT

Fail-Safe: For fail safe operation, an active low is required. If the monitor detects an operator-grounding fault, the open collector port goes low (with respect to the green wire ground).

One-Wire: Since the monitor detects that there is a low resistance between the green wire ground and the neutral conductor in the branch circuit, less than 1K ohms, the green wire ground serves as the reference or the second wire between the monitor and its remote warning device. The open collector port is the other.

Specifications:

V (open circuit)	<20 V
I (short circuit)	200 uA
Pull-up to 15V	>50 uA (Active)
Pull-up to 5V	>150 uA (Active)
Pull-down to 0.5V	>400 uA (Active)
Third-state HiZ	>100 K ohms (unit unplugged)

Maintenance and Calibration

The 41137 Dual Operator Workstation Continuous Monitor is solid state and designed to be maintenance free. The 41137 is calibrated to NIST traceable standards. There are no user adjustments that can be made. Because of the impedance sensing nature of the test circuit, special equipment is required for calibration. We recommend that calibration be performed annually, using the #41121 Continuous Monitor Calibration Unit. **Prior to calibration, disconnect Remote Jacks (if used) from the unit. Remote Jacks may cause intermittencies in calibration.** The Calibration Unit is a most important product which allows the customer to perform NIST traceable calibration on continuous monitors. The #41121 is designed to be used on the shop floor at the workstation, virtually eliminating downtime, verifying that the continuous monitor is operating within tolerances.

Limited Warranty

ESD Systems.com expressly warrants that for a period of five (5) years from the date of purchase, our Continuous Monitors will be free of defects in material (parts) and workmanship (labor). Within the warranty period, a credit for purchase of replacement ESD Systems.com Continuous Monitors, or, at our option, the Continuous Monitor will be repaired or replaced free of charge. If product credit is issued, the amount will be calculated by multiplying the unused portion of the expected five year life times the original unit purchase price. Call Customer Service at 508-485-7390 for a Return Material Authorization (RMA) and proper shipping instructions and address. You should include a copy of your original packing slip, invoice, or other proof of purchase date. Any unit under warranty should be shipped prepaid to the ESD Systems.com factory. Warranty replacements will take approximately two weeks.

If your unit is out of warranty, ESD Systems.com will quote repair charges necessary to bring your unit up to factory standards. Call Customer Service at 508-485-7390 for a Return Material Authorization (RMA) and proper shipping instructions and address.

Warranty Exclusions

THE FOREGOING EXPRESS WARRANTY IS MADE IN LIEU OF ALL OTHER PRODUCT WARRANTIES, EXPRESSED AND IMPLIED, INCLUDING MERCHANTABILITY AND FITNESS FOR A PARTICULAR PURPOSE WHICH ARE SPECIFICALLY DISCLAIMED. The express warranty will not apply to defects or damage due to accidents, neglect, misuse, alterations, operator error, or failure to properly maintain, clean or repair products.

Limit of Liability

In no event will ESD Systems.com or any seller be responsible or liable for any injury, loss or damage, direct or consequential, arising out of the use of or the inability to use the product. Before using, users shall determine the suitability of the product for their intended use, and users assume all risk and liability whatsoever in connection therewith.



Visit our online
library of Tech Briefs:
<http://www.esdsystems.com>

 **ESD SYSTEMS.com**

19 BRIGHAM ST. UNIT 9
MARLBORO, MA 01752-3170
PHONE (508) 485-7390
FAX (508) 480-0257